

General Description

Threaded Cartridge Style Counterbalance Valve, Semi-Restrictive Ports 2 to 3. Pilot assisted, designed for motion control applications. For additional information see Technical Tips on pages LM2-LM5.

Features

- Poppet construction for minimal leakage
- Incorporates direct acting relief valve for overload protection
- Includes reverse check valve within body, saving space and minimizing installation cost
- Excellent control and very good stability
- Fully sealed pilot for high efficiency and accurate pilot ratio
- Three pilot ratios available, 1.5:1, 3:1 and 4.5:1
- Hardened working parts for maximum durability
- All external parts zinc plated

Specifications

Rated Flow	Free flow 60 LPM (16 GPM) Piloted open flow 38 LPM (10 GPM)
Pressure	40-350 Bar (580-5000 PSI)
Sensitivity: Pressure/Turn	104 Bar (1508 PSI)
Pilot Ratio	E2E1S - 1.5 : 1 E2K1S - 3 : 1 E2M1S - 4.5 : 1
Leakage at 150 SSU (32 cSt)	5 drops/min. (0.33 cc/min) @ 75% of thermal crack pressure
Cartridge Material	All parts steel. All operating parts hardened steel.
Operating Temp. Range/Seals	-34°C to +121°C (Nitrile) (-30°F to +250°F) -26°C to +204°C (Fluorocarbon) (-15°F to +400°F)
Fluid Compatibility/Viscosity	Mineral-based or synthetic with lubricating properties at viscosities of 45 to 2000 SSU (6 to 420 cSt)
Filtration	ISO-4406 18/16/13, SAE Class 4
Approx. Weight	0.17 kg (0.37 lbs.)
Cavity	CAVT11A (See BC Section for more details)

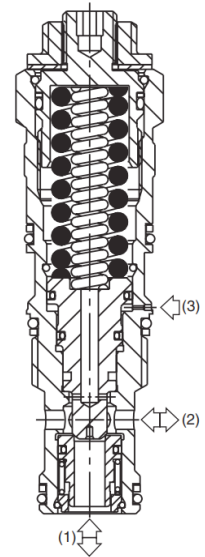
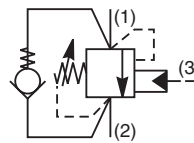
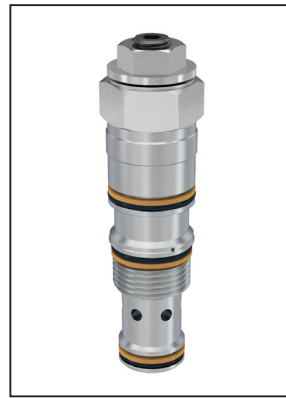

Performance Curves
Relief Performance 1 to 2

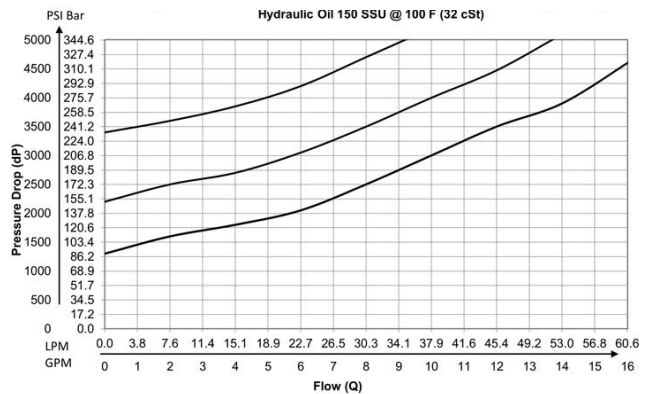

Pressure Drop vs. Flow

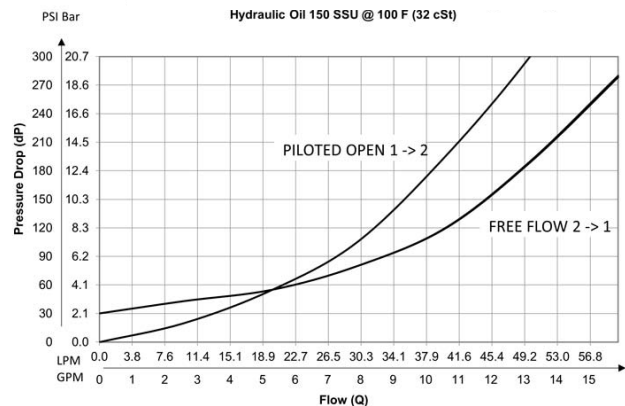

Required Piloted Pressure Calculation

$$P_3 = \left(\frac{P_C - P_1}{P_R} \right) + P_2 * \left(\frac{1}{P_R} + 1 \right)$$

P_C = Crack Pressure Setting
 P_R = Pilot Ratio

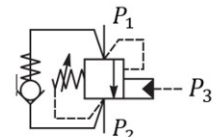

- CV**
Check Valves
- SH**
Shuttle Valves
- LM**
Load/Motor Controls
- FC**
Flow Controls
- PC**
Pressure Controls
- LE**
Logic Elements
- DC**
Directional Controls
- SV**
Solenoid Valves
- PV**
Proportional Valves
- CE**
Coils & Electronics
- BC**
Bodies & Cavities
- TD**
Technical Data

Dimensions Millimeters (Inches)

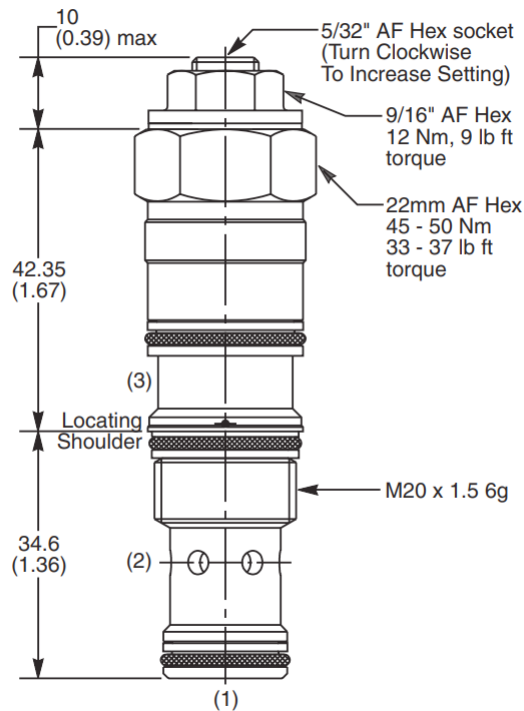

Ordering Information

E2		1S	Z	N
Load Control Valve	Pilot Ratio	Adjustment Style	Seals	

Highlighted represents preferred options that offer the shortest lead times. Other options may be available, but at extended lead times.

Code	Pilot Ratio
E	1.5 : 1
K	3 : 1
M	4.5 : 1

Code	Adjustment Style
Z	Screw Adjust (standard)

Code	Seals
N	Nitrile

Order Bodies Separately See section BC

LB10	825	S
Line Body	Porting	Body Material

Code	Porting
825	1/2" SAE (main) 1/4" SAE (aux)

Code	Body Material
S	Steel /(5000PSI)

Kit	Part Number
Tamper Resistant Cap	TC1130
Nitrile Seal	SK30008N-1
Fluorocarbon Seal	SK30008V-1

**Standard valve is set to crack at 215 Bar (3120 PSI). Valve to be set to 1.3 times maximum load induced pressure.*

CV
Check Valves
SH
Shuttle Valves
LM
Load/Motor Controls
FC
Flow Controls
PC
Pressure Controls
LE
Logic Elements
DC
Directional Controls
SV
Solenoid Valves
PV
Proportional Valves
CE
Coils & Electronics
BC
Bodies & Cavities
TD
Technical Data